

IMPORTANT SAFETY RULES

Read, understand, and follow all instructions carefully before installing and using this product. Keep for future reference.

Automatic Pool Cleaner ZX50

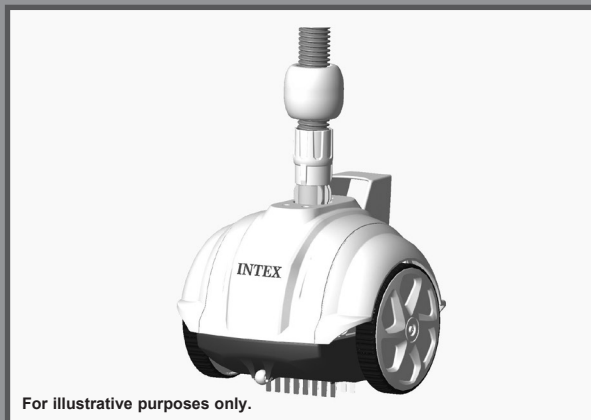

Don't forget to try these other fine Intex products: pools, pool accessories, inflatable pools and in-home toys, airbeds and boats available at fine retailers or visit our website.

Due to a policy of continuous product improvement, Intex reserves the right to change specifications and appearance, which may result in updates to the instruction manual without notice.

OWNER'S MANUAL

INTEX®

©2024 Intex Marketing Ltd. - Intex Development Co. Ltd. - Intex Recreation Corp. All rights reserved/Tous droits réservés/Todos los derechos reservados/Alle Rechte vorbehalten. Printed in China/Imprimé en Chine/Impreso en China/Gedruckt in China.

®™ Trademarks used in some countries of the world under license from/®™ Marques utilisées dans certains pays sous licence de/Marcas registradas utilizadas en algunos países del mundo bajo licencia de/Warenzeichen verwendet in einigen Ländern der Welt in Lizenz von/Intex Marketing Ltd. to/a/a/an Intex Development Co. Ltd., Hong Kong & Intex Recreation Corp., P.O. Box 1440, Long Beach, CA 90801 • Distributed in the European Union by/Distribué dans l'Union Européenne par/Distribuido en la unión Europea por/Vertrieb in der Europäischen Union durch/Intex Trading B.V., Ettenseweg 46, 4706 PB Roosendaal - The Netherlands • Distributed in the UK by Unites Service (UK) Limited, 21 Holborn Viaduct, London EC1A 2DY, UK.

www.intexcorp.com

078-A*-R0-2505

TABLE OF CONTENTS

Warnings	3
Parts Reference	4
Set Up Instructions	5-8
Debris Net Cleaning	9-10
Troubleshooting Guide	11-12
Long Term Storage	13
General Aquatic Safety	13

SAVE THESE INSTRUCTIONS

IMPORTANT SAFETY RULES

**Read, Understand and Follow All Instructions Carefully
Before Installing and Using this Product.**

⚠ WARNING

- TO REDUCE THE RISK OF INJURY, DO NOT PERMIT CHILDREN TO USE THIS PRODUCT.
- REMOVE THE PRODUCT FROM THE POOL WHILE THE POOL IS OCCUPIED OR IN USE.
- TURN OFF OR UNPLUG THE FILTER PUMP BEFORE ADJUSTING, CLEANING OR SERVICING.
- REMOVE THE PRODUCT FROM THE POOL BEFORE PLACING A POOL COVER OVER THE POOL.
- STORE THE PRODUCT AND ACCESSORIES IN A DRY AND SAFE PLACE INDOORS.
- FOR POOL AND FILTER PUMP PROBLEMS REFER TO THEIR RESPECTIVE OWNER'S MANUAL FOR ADVICE.
- THIS DEVICE IS INTENDED TO BE USED ONLY FOR THE PURPOSES DESCRIBED IN THE MANUAL.

FAILURE TO FOLLOW THESE WARNINGS MAY RESULT IN PROPERTY DAMAGE, SERIOUS INJURY OR DEATH.

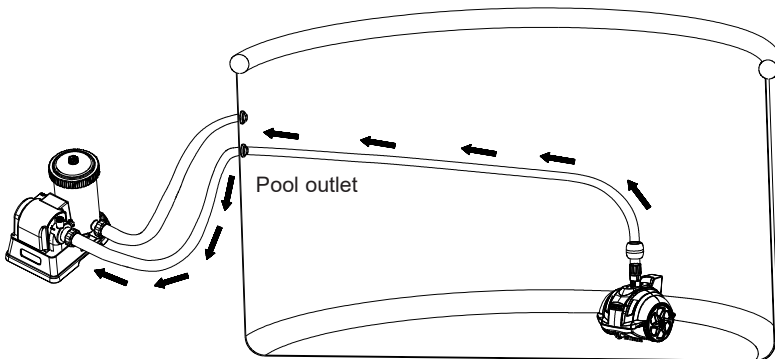

SAVE THESE INSTRUCTIONS

PARTS REFERENCE

Before assembling your product, please take a few minutes to check the contents and become familiar with all the parts.

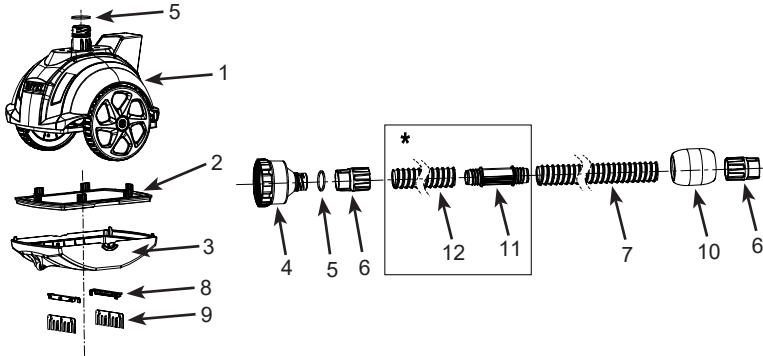

NOTE: Drawings for illustration purpose only. Actual product may vary.
Not to scale.

REF. NO.	DESCRIPTION	QTY.	SPARE PARTS NO.
1	CLEANER TOP	1	13121
2	DEBRIS NET	1	13122
3	CLEANER BASE	1	13123
4	HOSE ADAPTOR	1	12859
5	CAP SEAL O-RING	2	12861
6	HOSE COLLAR NUT	2	13124
7	HOSE	1	13125
8	BRUSH SUPPORT (WITH 2 EXTRA)	4	13126
9	BRUSH (WITH 10 EXTRA)	12	13127
10	FOAM FLOAT	1	13130
11*	EXTENSION HOSE CONNECTOR (NOT INCLUDED)	1	13139
12*	EXTENSION HOSE (WITH #11) (NOT INCLUDED)	1	13141

" * ": These parts are available for purchase separately when using the device with 18 ft (5.49 m) & 20 ft (6.1 m) diameter pools. Contact our Authorized Service Centers to order these parts if needed. When ordering parts, be sure to quote the model number and part numbers.

SAVE THESE INSTRUCTIONS

SETUP INSTRUCTIONS

IMPORTANT PREPARATION INFORMATION

Please read, understand, and follow all instructions carefully before installing and using this product.

General

- The Auto Cleaner operates from the suction side of the pool water outlet connector (water flowing from the pool to the filter pump).
- If an Intex Saltwater System or Ozone Generator is attached to the pool, disconnect these sanitation devices from the circulation line first before operating the Auto Cleaner. Once the Auto Cleaner has finished cleaning the pool, disconnect, remove the Auto Cleaner from the pool and resume the sanitation device operation.
- The Auto Cleaner must be connected to a filter pump with a flow rate between 900 - 1500 gallons/hour (3407 - 5678 liters/hour).
- For Intex® above ground frame pools with 1-1/2" (38 mm) and 1-1/4" (32 mm) threaded strainer connector hose fitting.
 - Up to 16 ft (4.9 m) round shape.
 - Up to 20 ft x 10 ft (6.1 m x 3.05 m) rectangular/oval shape.
 - For 18 ft (5.49 m) and 20 ft (6.1 m) round pools, a separate extension hose (**12**) is required. Contact your nearest local service centers to purchase this part.
- First assemble your filter pump and then set up the auto cleaner.
- The auto cleaner will not work if the filter pump is not operating.
- The auto cleaner is designed to clean the pool as follow:
 - The brushes from the auto cleaner remove the fine dirt from the floor.
 - The fine sediments and debris on the floor are agitated by the auto cleaner movement. This allows the filtration system to filter out the fine sediments suspended in the water, while the auto cleaner pick up the heavy debris on the floor.
 - The movement of the auto cleaner around the pool prevents the water from stagnating. Thus helping circulate the pool water through the filtration system.

SAVE THESE INSTRUCTIONS

SETUP INSTRUCTIONS (continued) English

78
A

Before setup, make sure that:

- The filter pump is turned off, and disconnect the power cord from the electrical outlet.
 - The pool is free from objects that will hinder the auto cleaner free movements by removing the ladder, surface skimmer, water sprayer (if applicable), floats or any other objects from the pool.
 - The pool wall or floor are free from algae. Algae will cause the wheels to slip, block the flow of water into the cleaner and hinder the auto cleaner movement. Treat the pool water with algacide and wait for the algae to shed before using the auto cleaner. See your local pool supply specialist for algae treatment solutions. Check and clean the debris net more frequently.
1. Remove the suction outlet strainer grid from the strainer connector and put it in a safe place. Attach the hose adaptor (4) to the water outlet strainer connector. See Fig. 1.

NOTE: The device operates from the suction side of the pool water outlet connector (water flowing from the pool to the filter pump).

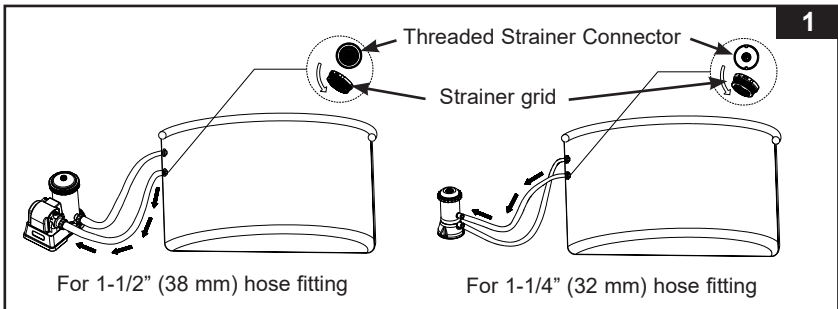

2. Screw the hose adaptor (4) to the threaded strainer connector, from inside of the pool. See Fig. 2.

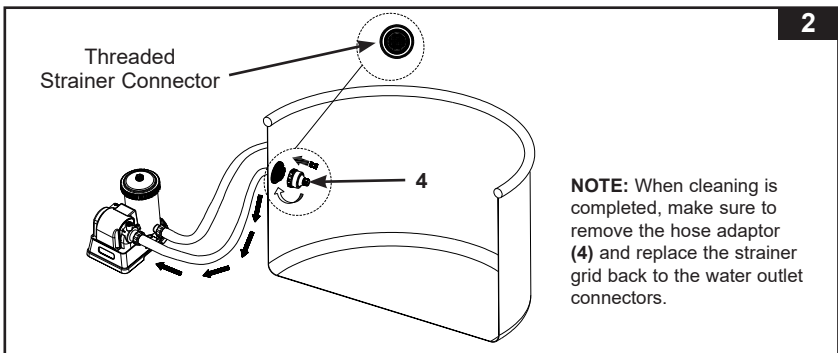

SAVE THESE INSTRUCTIONS

SETUP INSTRUCTIONS (continued)

3. Screw the hose collar nuts (6) and foam float (10) to the hose (7). See Fig. 3.

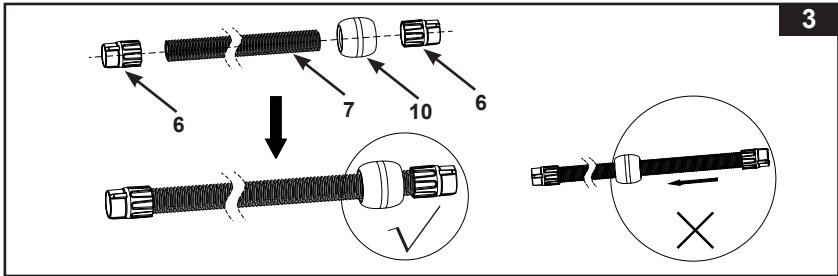

4. Brush assembly. See Fig. 4.

NOTE: Remove the brushes from underneath the device when vacuuming large debris or leaves on the pool floor.

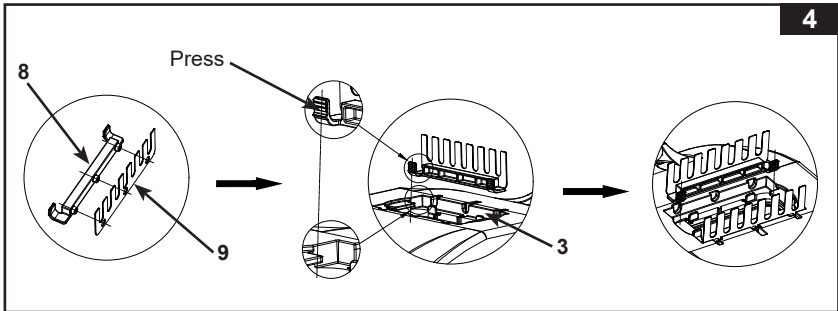

5. From outside of the pool, connect the end of the hose with the hose collar nut (6) and foam float (10) to the auto pool cleaner water outlet. Hold the rim on the cleaner top (1) first, then vertically insert the hose collar nut (6) into the water outlet opening, turn the hose collar nut (6) clockwise to tighten the hose. To remove the hose, turn the collar nut counter-clockwise. See Fig. 5.

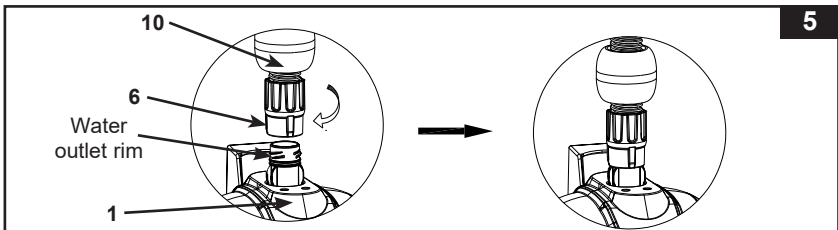

SAVE THESE INSTRUCTIONS

SETUP INSTRUCTIONS (continued)

English

78
A

6. Venting the system is necessary for air to escape as the auto cleaner fills with water. Hold the auto cleaner handle and slowly lower it into the pool water. Hold the hose vertically and slowly submerge the hose into the water section by section to remove all the trapped air in the hose. See Fig. 6.

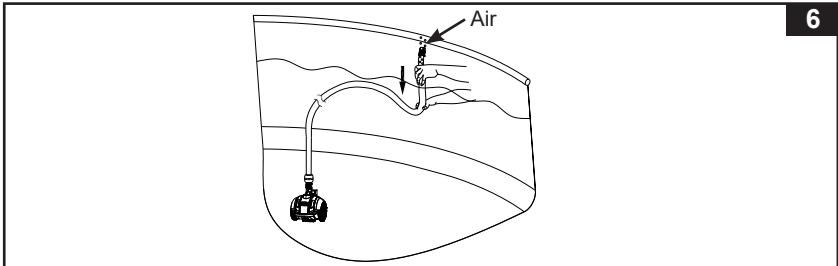

7. Once all the air has been released from the hose and the auto cleaner, attach the other end of the hose to the hose adaptor (4). See Fig. 7. When water begins flowing into the filter pump, open the air release valve on top of the filter pump cartridge chamber cover, lift and lower the pump hoses until water begins flowing out of the air release valve. Close the air release valve back. **Refer to the filter pump manual for more details.** This will evacuate all the air in the hose and auto cleaner, so the auto cleaner will stay on the pool floor. Stretch out the hose by slowly pulling the auto cleaner across the pool to the opposite side. Make sure the hose is stretched out in order to prevent any entanglement.

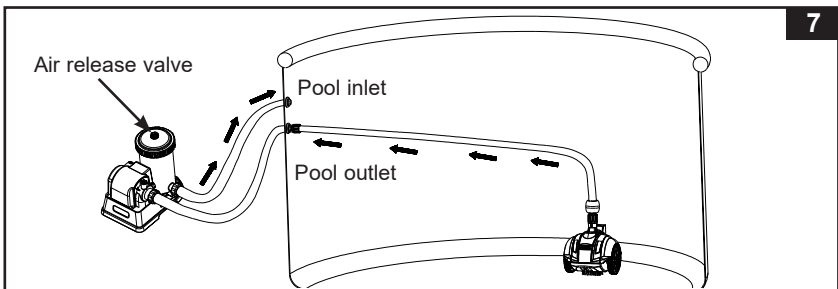

8. Turn on the filter pump. The auto cleaner is now moving and vacuuming the pool floor.
Note: The cartridge filter pump and sand filter pump will clean the pool water. It's essential to clean or replace the filter cartridge or backwash sand media frequently to keep the water clean. The auto cleaner route pattern timing depends on the filter pump flow rate. A higher pump flow rate will result in faster route timing.

SAVE THESE INSTRUCTIONS

DEBRIS NET CLEANING

1. Make sure the filter pump is turned off, and disconnect the power cord from the electrical outlet.
2. Lift the auto cleaner's hose slowly then hold the auto cleaner up with one hand. See Fig. 8-9.
CAUTION: Do not pull the hose directly which could damage the auto cleaner hose connection fitting.
3. Once all the water has been released from the auto cleaner, hold the rim with one hand and turn the hose collar nut **(6)** counter-clockwise to remove the hose from the auto cleaner. See Fig. 10.
4. Remove the auto cleaner from the pool and place it on the ground. See Fig. 11.

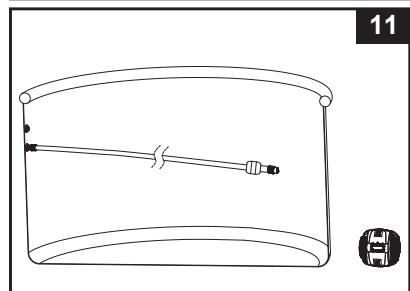
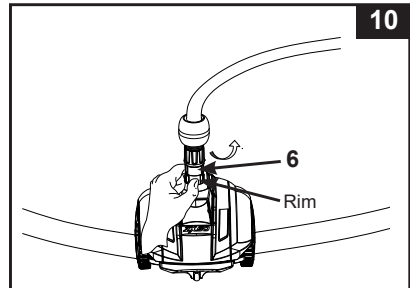
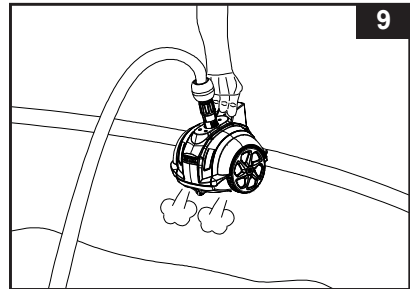
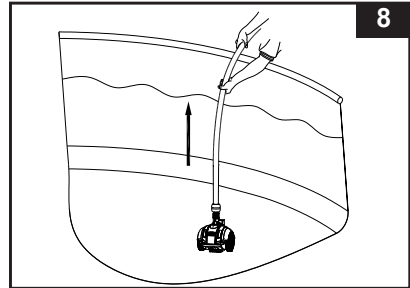

SAVE THESE INSTRUCTIONS

DEBRIS NET CLEANING (continued)

5. Push the left and right levers to the unlock position. See Fig. 12.

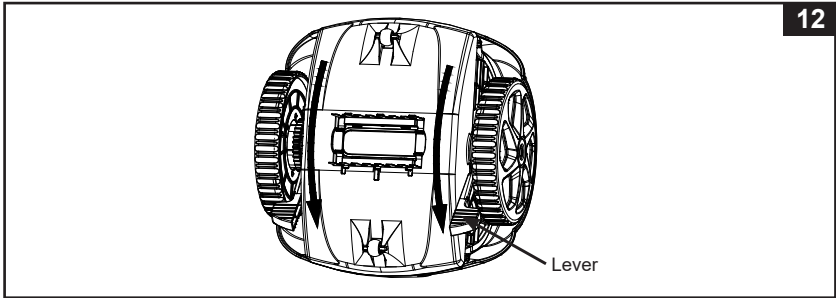

6. Remove the debris net (2) from the cleaner base (3). If debris is on the debris net and cleaner base, use a garden hose to flush the debris off. See Fig. 13.

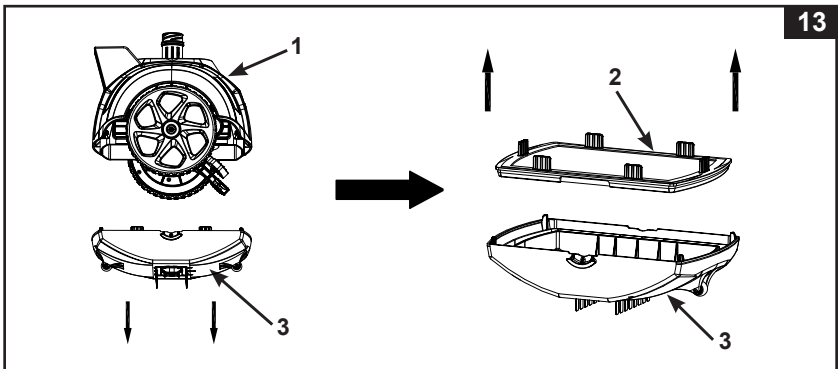

7. Reassemble auto cleaner debris net and base by reversing previous steps.

IMPORTANT NOTE

If the auto cleaner starts to stir the debris, sediments on the pool floor, you will require to clean or replace the filter cartridge more frequently as the fine sediments are retained by the cartridge. Also clean the debris net (2) frequently.

SAVE THESE INSTRUCTIONS

TROUBLESHOOTING GUIDE

English

**78
A**

TROUBLE	SOLUTION
AUTO CLEANER DOESN'T MOVE	<ul style="list-style-type: none"> • Ensure the filter pump is operating and within the specified pump flow rate [900 - 1500 gallons/hour (3407 - 5678 liters/hour)]. • Lift the auto cleaner out of the water and check if water is flowing out from the "water outlet" located on the top of the device. • Tighten the hose collar nut securely, and connect the hose to the pool water outlet connector, see "Setup" section. • Remove the cleaner base, check if the gear box is stuck, turn the wheels by hand and see if the wheels rotate, if not, replace a new unit. • Evacuate all the trapped air in the filter pump and filter pump hoses. • Contact Intex Service Center.
HOSE IS ENTANGLED OR CURLED UP	<ul style="list-style-type: none"> • If the hose is coiled in a circle, it will not affect the auto cleaner movement around the pool. This is normal. • However, if the hose is entangled or twisted, this will hinder the auto cleaner movement. Stretch out the hose by slowly pulling the auto cleaner across the pool to the opposite side. Make sure the hose is stretched out before operating the auto cleaner. • Alternatively disconnect the hose from the pool and the auto cleaner, stretch out the hose on a flat surface and let it warm up under the sun (24 hours) before using it.
MOVEMENT IS VERY SLOW	<ul style="list-style-type: none"> • Check and clean the debris net and micro-screen. • Clean or replace the filter pump cartridge. • If using a sand filter, ensure the sand media is clean by backwashing it. See sand filter owner's manual.
LIFTS OFF FROM THE POOL FLOOR	<ul style="list-style-type: none"> • Evacuate all the air in the hose and auto cleaner, see "Setup" section. • Pool water too dirty or the wall is covered with algae. Ensure the pool water chemistry is balanced. If the pool water is green, brown or black, adjust the chlorine and pH level. See pool owner's manual. • Check if the pump flow rate is within the specified range, if the flow rate is less than 900 gal/h (3407 liters/h), change the pump with a higher pump flow rate.
CAN NOT PICK UP THE LEAVES ON POOL FLOOR	<ul style="list-style-type: none"> • Remove the brushes from the underside and put the Auto Cleaner back into the pool, see "Setup" section. • Clean all the debris from the Auto Cleaner after operating for 2-3 hours continuously.

SAVE THESE INSTRUCTIONS

TROUBLESHOOTING GUIDE (continued)

TROUBLE	SOLUTION
TAKES LONGER TIME TO REVERSE DIRECTION	<ul style="list-style-type: none">• This is normal, as the auto cleaner reversing time is dictated by the size of the filter pump flow rate.
SEDIMENTS ARE STIRRED UP FROM THE POOL FLOOR	<ul style="list-style-type: none">• As the auto cleaner move around, fine sediments on the pool floor will be stirred up causing the water to be cloudy. This is normal.• Run the filtration system and the auto cleaner longer. The filtration system will filter out the fine sediments suspended in the water, while the auto cleaner will pick up the heavy debris on the floor. Check and clean the filtration media and the debris net more frequently.
DEBRIS NET IS CLOGGED AND AUTO CLEANER IS SHUT OFF	<ul style="list-style-type: none">• Present of algae in the pool. Treat the pool water with algaecide and wait for the algae to shed before using the auto cleaner. See your local pool supply specialist for algae treatment solutions. Check and clean the debris net more frequently.• Maintain proper pool water chemistry, see pool owner's manual for more details.

IMPORTANT

If you continue to experience difficulty, please contact our Consumer Service Department for assistance. See separate "Authorized Service Centers" sheet.

SAVE THESE INSTRUCTIONS

LONG TERM STORAGE

1. Make sure the filter pump is turned off, and disconnect the power cord from the electrical outlet.
2. Using the Set Up instructions in reverse, disassemble the auto cleaner.
3. Clean and air dry all the accessories and parts thoroughly.
4. Loosely roll up and avoid twisting the hose during storage. Do not put heavy objects on top of the hose.
5. Remove the brushes and keep them flat and straight during storage.
6. The original packaging can be used for storage. Store in a dry, cool storage location.

GENERAL AQUATIC SAFETY

Water recreation is both fun and therapeutic. However, it involves inherent risks of injury and death. To reduce your risk of injury, read and follow all product, package and package insert warnings and instructions. Remember, however, that product warnings, instructions and safety guidelines cover some common risks of water recreation, but do not cover all risks and or dangers.

For additional safeguards, also familiarize yourself with the following general guidelines as well as guidelines provided by nationally recognized Safety Organizations:

- Demand constant supervision. A competent adult should be appointed as a "lifeguard" or water watcher, especially when children are in and around the pool.
- Learn to swim.
- Take the time to learn CPR and first aid.
- Instruct anyone who is supervising pool users about potential pool hazards and about the use of protective devices such as locked doors, barriers, etc.
- Instruct all pool users, including children what to do in case of an emergency.
- Always use common sense and good judgement when enjoying any water activity.
- Supervise, supervise, supervise.

SAVE THESE INSTRUCTIONS